

(00) 340382230000000009

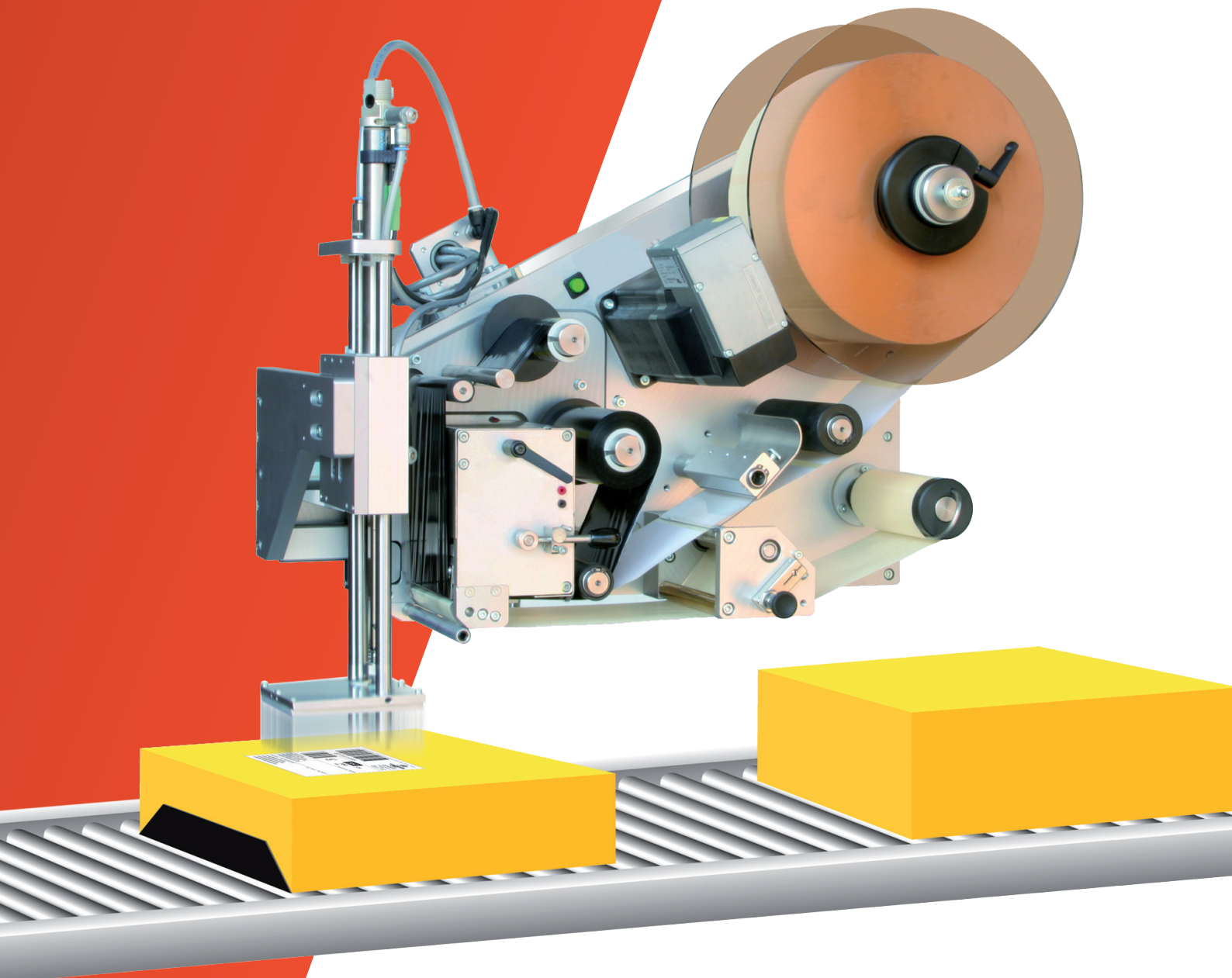

Logopak 410 T

Labeling for variable
height products



(00) 34038223000000009



Logopak 410 T

Printing characteristics

- ✓ Direct thermal transfer printing
- ✓ Printing resolution: 300 dpi (optional: 203 dpi)
- ✓ For labels with a print width of up to 4.3" (110 mm)
- ✓ Barcodes: all standard barcodes and 2D codes
- ✓ Logos
- ✓ **RFID retrofittable**

Operation

- ✓ NEK touchscreen for numeric entry
- ✓ Optional: TDI 10" color display – with touchscreen function – with alphanumeric entry
- ✓ Multilingual user interface
- ✓ Internal article database
- ✓ Integrated real-time clock
- ✓ Individually programmable counters
- ✓ Low label warning
- ✓ Fault diagnosis
- ✓ Compressed air monitoring
- ✓ Maintenance interval display
- ✓ Optional: barcode validation
- ✓ Optional: alarm pole
- ✓ Optional: emergency stop

Support and protective housing

- ✓ Optional: H-frame
- ✓ Optional: dust protection housing
- ✓ Optional: available in stainless steel and special colors

Interfaces

- ✓ Integrated Ethernet connection
- ✓ 4x high-speed RS-232 (optional: RS-422)
- ✓ Optional: profibus
- ✓ Digital I/O (potential-free outputs)

Application

- ✓ Vacuum applicator with floating plate
- ✓ Stroke: up to 19.7" (500 mm)
- ✓ For variable product heights
- ✓ Continuous labeling
- ✓ Cycle output of up to 50 labels/min., depending on the label format

Software

- ✓ Software family: LogoSoft
- ✓ Label design program: LEAP-Express
- ✓ Service and monitoring tool: Control-Center

Label material

- ✓ Up to 1,312' (400 m) running length
- ✓ External diameter: 11.4" +/- .2" (290 +/- 5mm)
- ✓ Label core: 3" (76,2 mm)

Ambient conditions

- ✓ Operating temperature: 40°F to 104°F (5°C to 40°C)
- ✓ Special solutions for demanding ambient conditions
- ✓ Humidity: 20% to 90% relative, non-condensing
- ✓ Electrical connection: 110 to 230 Volt; 50/60 Hz
- ✓ Compressed air: 90 psi (6 bar) dry, clean and oil-free

Certificates

- ✓ CE certified
- ✓ UL 508 (USA)

Spare parts/maintenance

- ✓ All wear and spare parts available for minimum of 10 years
- ✓ Spare part packages, training and maintenance agreements

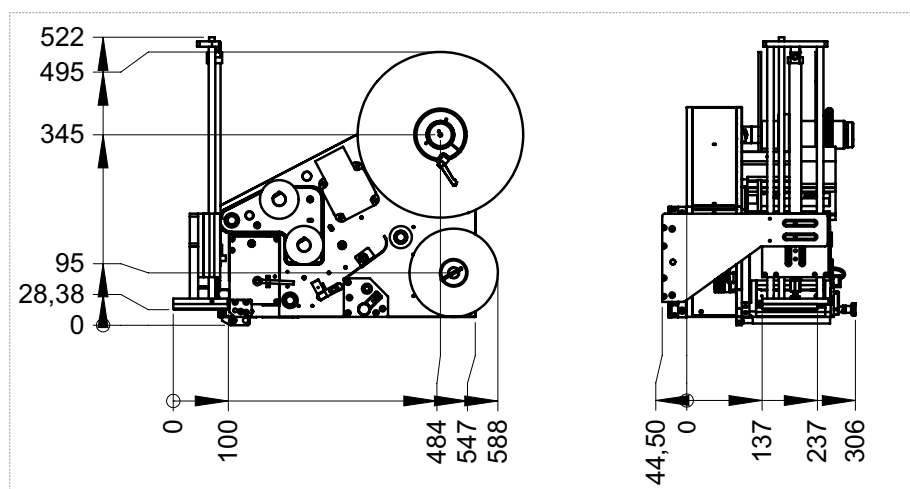

We reserve the right to amend the design and/or specifications of our product without notice.

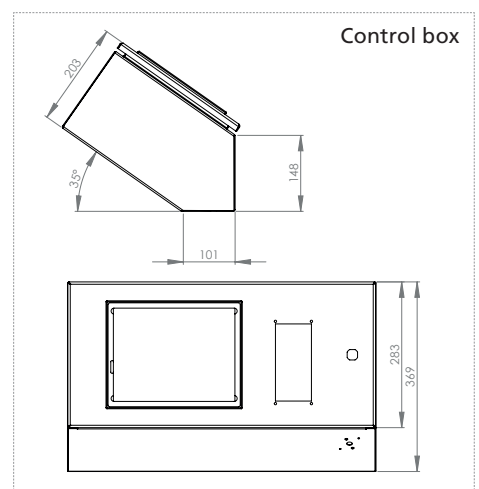

All dimensions in mm